



Global shape and sizing

Optimal AP – ML ratios for global patients

PS & CR Femurs (L & R)

	A	B	C	D	E	F	G	H
M/L	54.00	58.00	62.00	64.00	66.00	70.00	74.00	78.00
A/P	51.00	54.00	58.00	60.00	62.00	66.00	70.00	74.00

Transitional size 'D'

Patella Dia.
25, 28, 31, 34, 37 & 40 mm

Metal Back Tibial Trays

	1	2	3	4	5	6	7	8
M/L	59	62	66	66	71	72	76	78
A/P	40	40	42	46	48	50	52	54

Modularity of sizes along with compatibility of 2 size mix & match in critical sizes

Component modularity PS femur, metal-backed tibia trays & inserts

		Femoral Component Size									
		A	B	C	D	E	F	G	H		
Metal Back Tibial Tray Size	1	■	■	■	■					Tibial Liner Size / Match on Metal Back Tibial Tray Size	Thickness of Tibial Liner
	2	■	■	■	■						
	3		■	■	■	■					
	4			■	■	■	■				
	5				■	■	■	■			
	6					■	■	■	■		
	7						■	■	■		
	8							■	■		

Component modularity of all poly

		Femoral Component Size									
		A	B	C	D	E	F	G	H		
All-poly Tibial Component size	A1	■									
	B2		■								
	C2			■							
	C3				■						
	D2					■					
	D3						■				
	D4							■			
E4								■			
E5									■		
F5										■	
G7											■

Femoral Sizing Guide

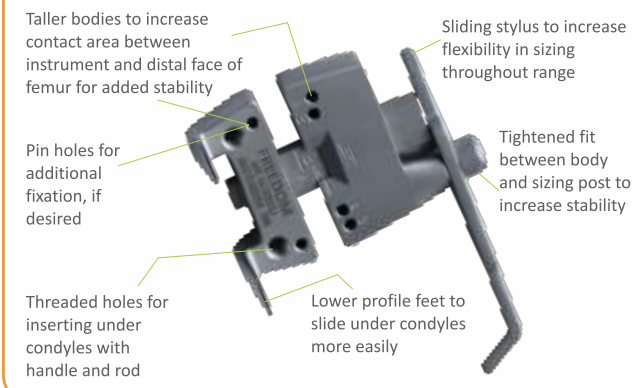

5-1 Cutting Block

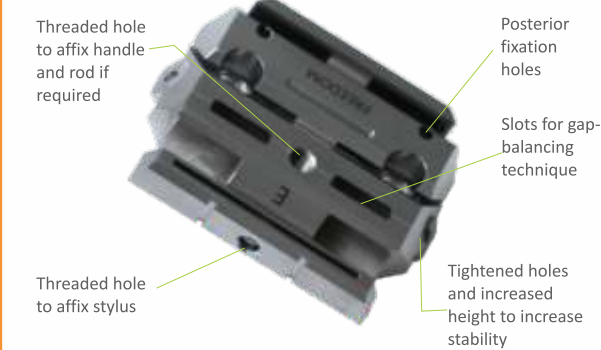

5-1 Cutting Blocks with Stylus

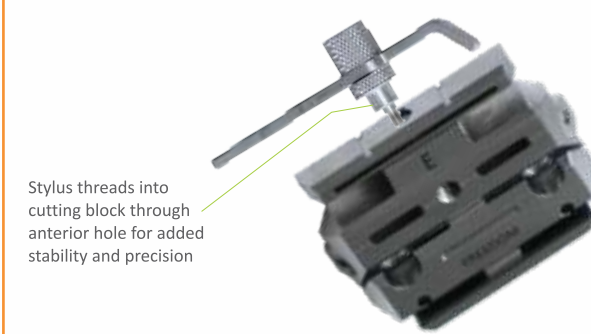

5-in-1 Line to Line with Femur

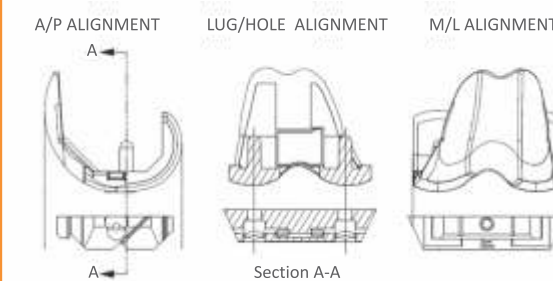

For more information about Freedom Knee® please contact your local representative.

Please see the package insert for complete device description, product selection information, indications, contraindications, precautions, adverse effects, warnings, materials, sterilization and patient guidance associated with the Freedom Total Knee® System.

CAUTION: THIS DEVICE IS RESTRICTED TO SALE BY OR ON THE ORDER OF A LICENSED PHYSICIAN

WARNING: THIS DEVICE IS INTENDED FOR CEMENTED USE ONLY

Freedom Knee® is manufactured by Maxx Orthopedics, Inc. FREEDOM and FREEDOM KNEE are Registered Trademarks of Maxx Orthopedics, Inc.

© 2012 Maxx Orthopedics. All rights reserved. Updated January 2012.

maxx www.maxxmed.com

Freedom Knee Design Rationale



- The one & only 7 radii knee implant in the world
- Optimised A-P & M-L ratios for femur & tibia
- Asymmetrical cam & post mechanism for rotation up to 15 degree
- 6 degree deep trochlear groove
- Thin anterior flange
- Small femoral box profile
- Small femoral posterior condyle resection
- Extended 7th radii in the posterior condyle
- 5 point cobalt chrome tibial locking system with 3 degree & 30 mm keel
- Minimized surface roughness of 11 um for tibial trays for superior finish
- Ram extruded poly UHMWPE, GUR 1020
- Modularity of sizes & compatibility



The one and only 7 radii femoral implant in the world: Facilitates coordinate articular geometry of natural femur

Coordinate articular geometry of the Freedom[®] femur 7 tangent radii ensures uniform load dissipation through optimised area contact

Radii 1, 2 and 3 ensure optimized patella-femoral contact.

They must be tightly controlled for smooth tracking over a thin anterior flange for optimized extensor mechanism & also minimizing the contact stress through uniform load dissipation.

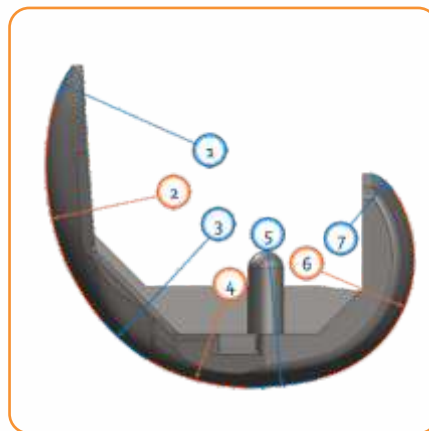

Radii 4, 5, 6 and 7 control femoral rollback and flexion over a wide array of biomechanical requirements, from walking to climbing stairs & ensure optimized area contact for uniform load dissipation both in extension & flexion thereby minimizing the contact stress.

The Freedom femoral design is based on functional principles of progressive multi-radii of Patello-femoral and Tibio-femoral contact areas

7 radii along with thin anterior flange and 6 degree deep trochlear groove facilitate predictable Patello-femoral tracking resulting in smooth extensor mechanism



Smooth extensor mechanism helps in reducing anterior knee pain.

Multi radii design for predictable femoral roll back and high flexion

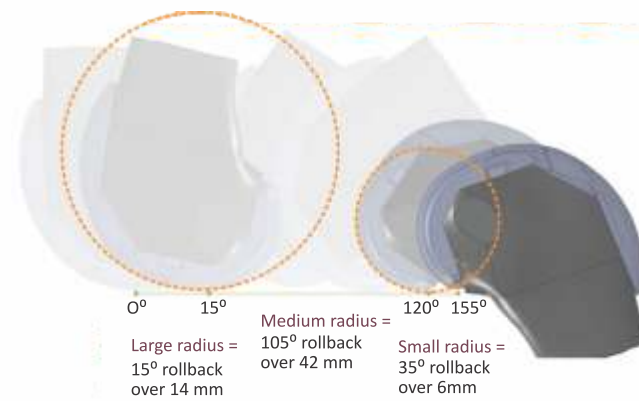

Increased femoral roll back allowing high flexion up to 155 degree for various daily & social activities.

Asymmetrical post-cam mechanism for rotation at deep flexion

A modified post-cam mechanism allows for stability, posterior clearance and protection against subluxation during deep flexion.

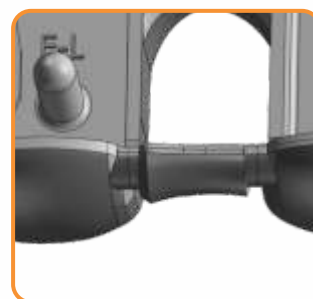
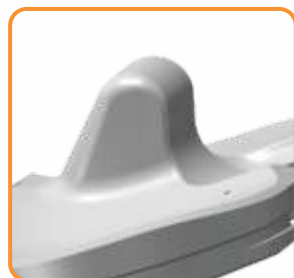

Achieves rotation up to 15 degree at deep flexion to prevent post-cam impingement, thereby reducing wear and tear of poly.

Prevention of edge loading at deep flexion

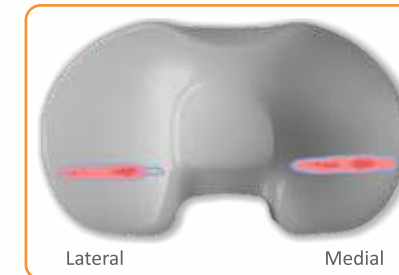

Representative Surface Stress Distribution 15 - 40+ MPa at 90 Degree Flexion, 333 kgf Load

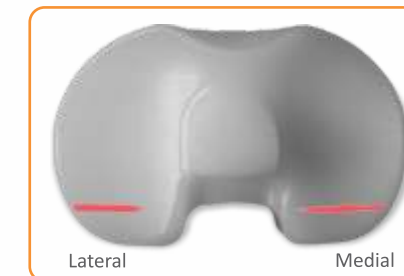

Representative Surface Stress Distribution 15 - 40+ MPa at 135 Degree Flexion, 222 kgf Load

Freedom Knee concentrates load towards the center of the poly.

Minimised micro motion in tibia

- 5 point locking mechanism and Optimized inside surface roughness average (11 um).
- Minimizes micro motion in tibia, thus reducing the back side wear in the tibial tray thereby improving the durability of the implant.

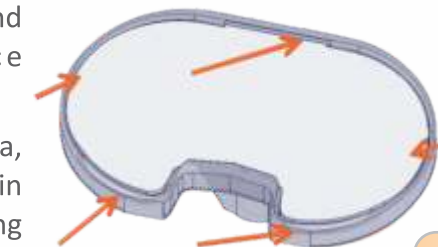

Both Freedom[™] CR and PS Tibial Inserts have identical locking mechanisms to mate.

Intelligent design for bone conservation

Thin anterior flange, low profile box and multi-radii design for minimized posterior condylar resection results in maximum bone conservation.

Freedom Knee: Post condylar bone resection (mm)

A	B	C	D	E	F	G	H
7.2	7.7	8.2	8.5	8.8	9.4	9.8	10.4

Freedom Knee: Box cut bone resection (cm³)

A	B	C	D	E	F	G	H
4.37	5.42	6.44	7.14	7.91	9.69	11.26	13.44

Importance of design in increasing implant longevity/ durability

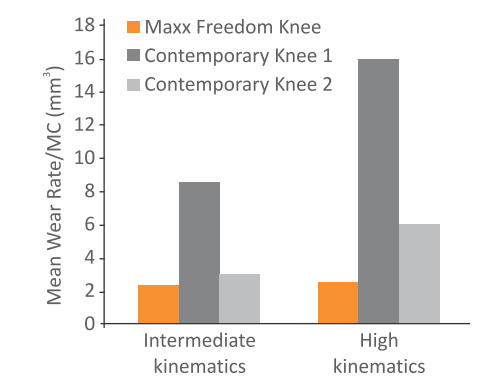

Source: White paper on comparative Lab Test Data on polywear characteristics